

FORGED AND CNC MACHINED STEEL COMPETITION WRIST PINS



Our **Steel Competition Wrist Pins** are **forged** from special **aerospace quality steel alloy**. Special **heat-treatment, ground and rolled exterior**, and **radius edges** ensure strength and reliability. Each pin is then **individually ultrasonic tested** as a part of our Quality Control.

The New **Pro-Series Wrist Pin**, made from ultra light, H-13 tool steel alloy, provides increased durability and longer life over other alloys. The new **H-13 Pro Pins** feature a superior surface finish for reduced wear on piston pin bores. These pins are CNC-machined to unparalleled tolerances and must pass a stringent quality control process. Available for spiral locks and/or chamfered for wire locks.

Compared to the machined piece, **our forged pin** presents a better molecular compactness, with the steel structure following the shape of the piece. In the machined pin, the material is cut by the machining process, increasing the risk of failure in the pin's critical area.

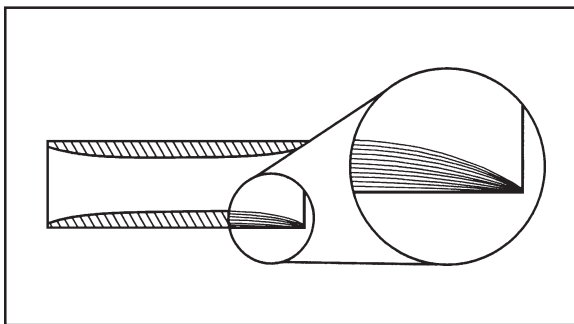

Fig. 1 Forged Wrist Pin

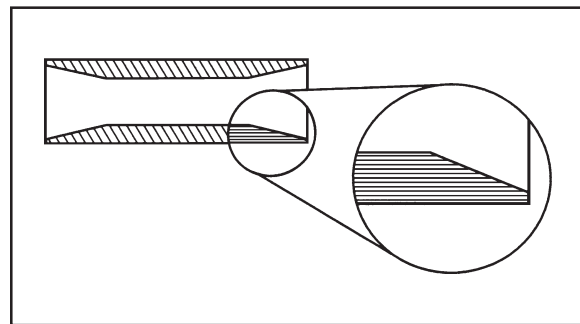

Fig. 2 Machined Wrist Pin

The difference in the material structure can be seen in fig. 1, which shows the cross section of **our forged wrist pin**, and in fig. 2, which shows the cross section of a machined pin.

FORGED AND CNC MACHINED STEEL COMPETITION WRIST PINS

Part Number	Diameter	Length	Wall Thickness	Weight	References
CHEVROLET BIG BLOCK					
P70060	.990	2.500	.168	123 grs.	Special Alloy. Ray Barton
P70051	.990	2.750	.165	134 grs.	H13 Special Alloy. Chamfered for wire locks.
P70005	.990	2.930	.150	130 grs.	Special Alloy
P70017	.990	2.930	.160	163 grs.	Straight Wall
P70028	.990	2.930	.168	138 grs.	Special Alloy
P70029	.990	2.930	.230	179 grs.	Nitrous applications
P70053	.990	2.930	.150	146 grs.	H13 Special Alloy.
P70059	.990	2.930	.180	154 grs.	H13 Special Alloy.
P70014	.990	3.000	.150	133 grs.	Special Alloy
P70026	.991	2.930	.150	132 grs.	Special Alloy
P70027	.992	2.930	.150	133 grs.	Special Alloy
P70022	.993	2.930	.150	129 grs.	Special Alloy
P70023	.994	2.930	.150	134 grs.	Special Alloy
CHEVROLET SMALL BLOCK					
P70000	.927	2.500	.148	104 grs.	Special Alloy
P70018	.927	2.500	.150	119 grs.	Straight Wall
P70030	.927	2.500	.125	95 grs.	Ultra Light. Special Alloy
P70045	.927	2.500	.125	92 grs.	H13 (Special Alloy)
P70048	.927	2.500	.130	100 grs.	H13 Special Alloy
P70050	.927	2.500	.109	87 grs.	H13 Special Alloy (Ultra Light)
P70054	.927	2.500	.150	105 grs.	H13 Special Alloy. Chamfered for wire locks.
P70057	.927	2.500	.150	106 grs.	H13 Special Alloy.
P70145	.927	2.500	.125	94 grs.	H13 Special Alloy. Chamfered for wire locks.
P70002	.927	2.750	.148	116 grs.	Special Alloy
P70019	.927	2.750	.150	131 grs.	Straight Wall
P70032	.927	2.750	.125	105 grs.	Ultra Light. Special Alloy
P70046	.927	2.750	.125	104 grs.	H13 (Special Alloy)
P70049	.927	2.750	.109	96 grs.	H13 Special Alloy (Ultra Light)

FORGED AND CNC MACHINED STEEL COMPETITION WRIST PINS

Part Number	Diameter	Length	Wall Thickness	Weight	References
CHEVROLET SMALL BLOCK					
P70055	.927	2.750	.150	117 grs.	H13 Special Alloy. Chamfered for wire locks.
P70058	.927	2.750	.150	117 grs.	H13 Special Alloy.
P70146	.927	2.750	.125	104 grs.	H13 Special Alloy. Chamfered for wire locks.
P70003	.927	2.950	.148	126 grs.	Special Alloy
P70020	.927	2.950	.150	141 grs.	Straight Wall
P70031	.927	2.950	.125	114 grs.	Ultra Light. Special Alloy
P70041	.927	3.000	.145	136 grs.	Straight Wall
P70001	.928	2.500	.148	104 grs.	Special Alloy
P70033	.928	2.500	.125	91 grs.	Ultra Light. Special Alloy
P70011	.928	2.750	.148	116 grs.	Special Alloy
P70004	.928	2.950	.148	126 grs.	Special Alloy
P70036	.928	2.950	.125	111 grs.	Ultra Light. Special Alloy
P70010	.929	2.500	.148	104 grs.	Special Alloy
P70034	.929	2.500	.125	92 grs.	Ultra Light. Special Alloy
P70021	.929	2.750	.148	120 grs.	Special Alloy
P70056	.929	2.750	.150	117 grs.	H13 Special Alloy. Chamfered for wire locks.
P70012	.929	2.950	.148	126 grs.	Special Alloy
P70037	.929	2.950	.125	111 grs.	Ultra Light. Special Alloy
P70035	.930	2.500	.125	92 grs.	Ultra Light. Special Alloy
P70038	.930	2.500	.148	108 grs.	Special Alloy
P70025	.930	2.950	.148	125 grs.	Special Alloy
FORD					
P70024	.912	2.500	.125	100 grs.	Special Alloy
P70062	.912	2.500	.125	97 grs.	H13 Special Alloy
P70047	.912	2.700	.115	87 grs.	H13 (Special Alloy)
P70052	.912	2.750	.109	95 grs.	H13 Special Alloy (Ultra Light)
P70063	.912	2.750	.125	107 grs.	H13 Special Alloy
MOTORCYCLES					
PM70042	17 mm	2.430	.115	61 grs.	Special Alloy
PM70043	18 mm	2.470	.115	66 grs.	Special Alloy
PM70044	18 mm	2.470	.200	100 grs.	Nitrous/Supercharged
SPECIAL SIZES					
P70009	.866	2.500	.118	78 grs.	Special Alloy
P70016	.990	3.125	.170	143 grs.	Special Alloy
P70040	1.031	2.750	.150	128 grs.	Special Alloy
P70006	1.031	2.850	.150	134 grs.	Special Alloy
P70061	1.032	2.750	.160	141 grs.	H13 Special Alloy. Camfered for wire locks. Special Heat Treat
P70007	1.040	3.125	.150	150 grs.	Special Alloy
P70039	1.094	2.750	.180	160 grs.	Special Alloy
P70008	1.094	3.100	.180	184 grs.	Special Alloy
P70015	1.094	3.100	.250	232 grs.	Nitrous applications